



# Low Maintenance Hook



## TRELLEBORG'S LOW MAINTENANCE HOOK

The new low maintenance range of quick release hook (QRH) builds on Trelleborg Marine Systems' renowned design to eliminate the reliance on manual greasing as the primary means of protection.

Operations that require long term mooring alongside a jetty, or have restricted access have created the requirement for a customized QRH, this upgrade consists of additional components being integrated into our standard hook either from new or as an upgrade, these hooks are designed specifically for operations where maintenance access is restricted or where there are extreme operating conditions.

**Our experience working within the LNG, Oil, Bulk and Offshore industries, across a broad spectrum of environmental and operational conditions, has led Trelleborg to engineer a QRH that is virtually maintenance free.**



DAM-LMH-01 Ver 1.0



Trelleborg Marine Systems' commitment to continuous product improvement means that we reserve the right to upgrade and modify equipment and systems without notice as technological and operational parameters demand.

## Features

- Key self lubricating locations
  - Load pin
  - Hook spigot
  - Primary trip lever
  - Cross shaft
- The design uses a combination of custom self-lubricating bushes and stainless steel sleeves to provide a low friction bearing surface for all moving parts. These components offer excellent corrosion resistance properties and are capable of providing years of greatly reduced or maintenance free operation.
- Available either as part of a new hook unit or as a kit for retrofit (requires rebuild).

## Benefits

- The elimination of greasing of multiple points on the QRH at three month intervals, therefore simplifying the maintenance process.
- Increased protection against hook seizures caused by long periods of no maintenance, dramatically reducing the risk of critical components failing and posing a safety hazard.
- Increased lifespan in comparison to a standard hook exposed to the same operating conditions.

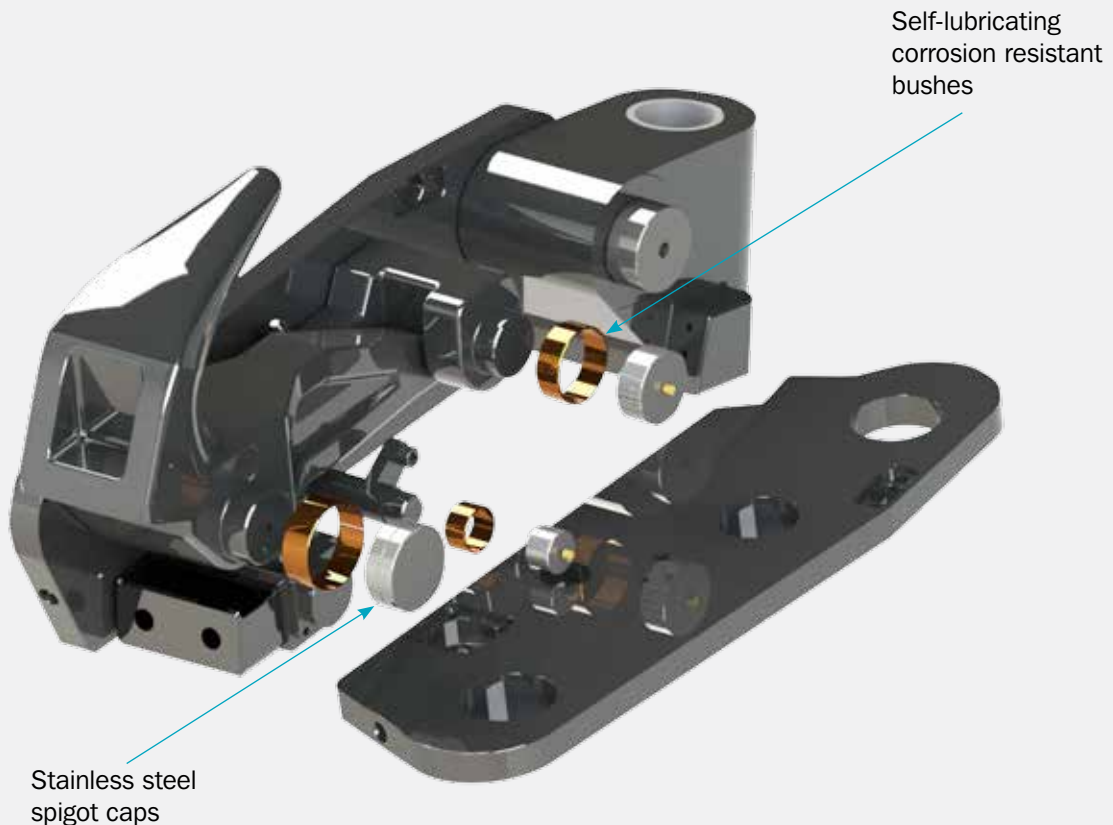

Website: [trelleborg.com/marineandinfrastructure](http://trelleborg.com/marineandinfrastructure)  
Email: [marine\\_infra@trelleborg.com](mailto:marine_infra@trelleborg.com)