

Omega seals

Trelleborg Ridderkerk BV



Contents

| | | |
|--------|--|----|
| 1 | Introduction | 3 |
| 2 | Design of an Omega Seal | 3 |
| 3 | Applications | 4 |
| 3.1 | Immersed tunnels | 4 |
| 3.2 | Bored tunnels | 5 |
| 3.3 | Aqueducts, canals, sluices and other applications | 6 |
| 4 | Product Range | 9 |
| 5 | Design application data | 10 |
| 6 | Clamping system | 10 |
| 7 | Policy quality, environment, safety and health | 11 |
| App. A | Standard range of Omega seal types | |
| App. B | Typical clamping system for Omega seals | |
| App. C | Diagram of allowable deflection and water pressure | |

Cover picture: Installation of an omega seal between a bored tunnel and a station.

1 Introduction

Since the 60's Trelleborg Ridderkerk B.V. has manufactured a large number of Omega seal joints. Originally the Omega Seal was designed as a secondary seal for immersed tunnels in combination with the Gina gasket/seal as the primary seal. Applications for the Omega Seal have now expanded to bored tunnels, aqueducts and ship lifts. Using the same construction techniques and materials as utilized in the original Omega shaped seal; the range has been expanded to flat seals. Trelleborg has manufactured a flat Omega seal 1.4 meter in width for an aqueduct in Germany! The Omega Seal provides the unique properties to withstand high water pressure in combination with large movements in all directions. The Omega Seal provides an ideal solution for joints where large gap movements are expected as a result of temperature effects and/or settlement.

2 Design of an omega seal

The construction of the standard Omega Seal consists of 2 nylon plies with SBR rubber cover on inside and outside, see figure 1. The allowed movement of the Omega depends on the pressure differential across the seal and the strength of the plies. In general the Omega is designed to allow axial and radial movements and/or rotation of the two bridged structures. Gap closure, an axial movement, will compress the arc of the Omega. An increase in the gap is limited by the circumference of the Omegas arc. The reinforcement of the Omega prevents elongation of the rubber. Vertical movements of the joint causes lateral deformation in the Omega seal. Rotation around the vertical axis of the structures causes compression in one vertical section and elongation in the other vertical section. To increase the movement capacity the Omega seal can be mounted with pre-compression.

Figure 1: Typical cross section Omega seal

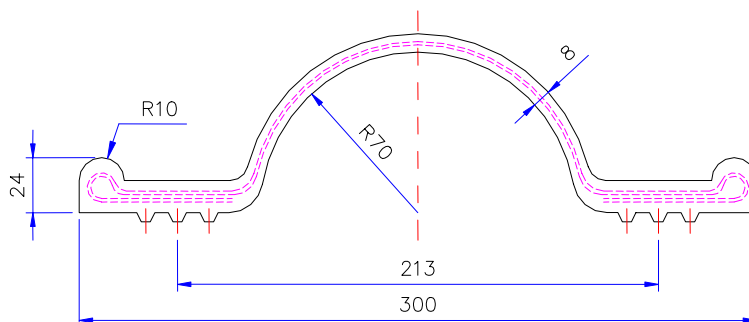

Based on the literature, the expected lifetime of an Omega seal is at least 100 years. The operating temperature should be within -30°C and $+70^{\circ}\text{C}$ and the rubber should not come into contact with particular chemicals such as hydrocarbons.

Trelleborg Ridderkerk is able to calculate from the force-compression curves and elongation limits at various water pressures; that the selected Omega seal satisfies the following conditions within agreed safety limits:

1. the Omega seal construction will withstand the water pressure, including the accommodation of the expected gap movements in three directions;
2. the steel clamping construction is capable to keep the Omega flange in position and sealing against the water pressure whilst at the same time allowing for all gap movements,
3. the clamping and sealing function of the clamping construction should incorporate the relaxation effect of the rubber flange over the expected tunnel lifetime period.

3 Applications

3.1 Immersed tunnels

Originally the Omega was designed as the secondary seal for applications in immersed tunnels. The primary seal, the so named Gina seal/gasket, is used to make the first contact between two tunnel elements, see figure 2. After pumping water out from between the bulkheads, the external hydrostatic force compresses the Gina, which results in a watertight joint. On the inside of the outer wall the Omega seal can now be installed, so that the tunnel elements are then physically connected. The complete fabricated Omega seal to suit a particular opening or gap is usually supplied as a rectangular shaped frame with sharp (radius 0) 90 degree corners and/or 135 degree corners. In general the frame is open to allow the Omega to be wrapped around the shear key. After installation a specialist of Trelleborg Ridderkerk vulcanises the closing joint on site.

Figure 2: Application of Gina gasket in combination with an Omega seal in an immersed tunnel

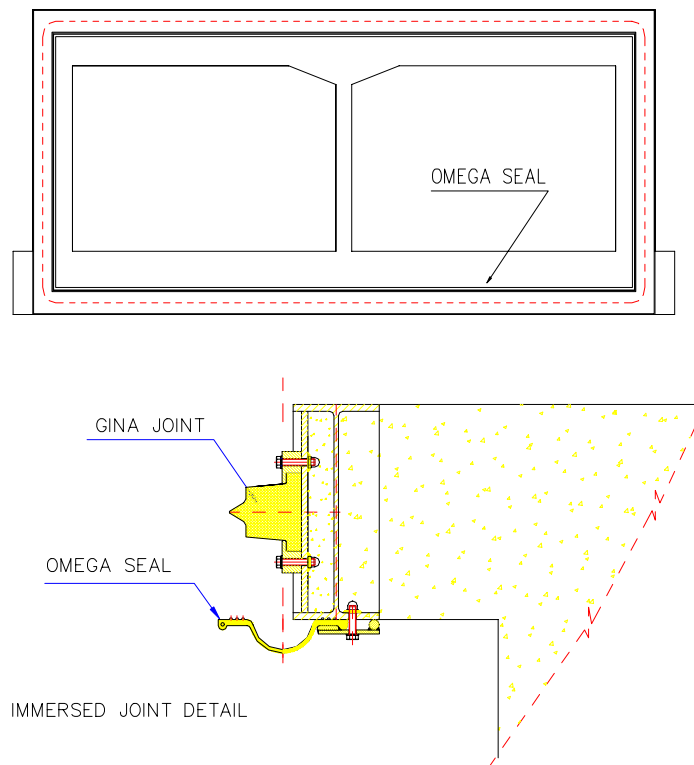

3.2 Bored tunnels

The Omega seal allows joint movement in combination with water pressure. Applications encompass the connection between a bored tunnel and the entrance to a structure such as a rail station, see. The bored tunnel is not under piled as opposed to the normal construction of a station, which results in differential settlement between the structures. For bored tunnels the Omega is often supplied as a closed ring.

Pictures 2 & 3: Application of an omega seal in a bored tunnel.

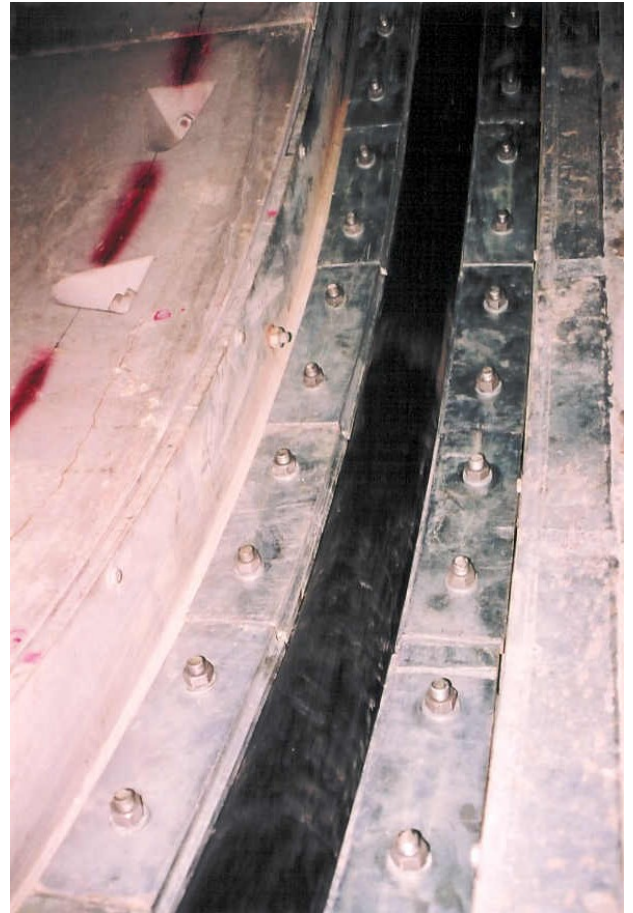

3.3 Aqueducts, canals, sluices and other applications

A third application of the seal, mainly the flat type, is where the seal is bent to a U shape and used in the joints of aqueducts. Due to temperature effects, the joints in an aqueduct construction will be subjected to considerable axial movements. In general the sealing system consists of an inner and an outer Omega, so that a double safety system is built in, see appendix 3. The Omega's are supplied in a U-shaped frame with sharp two 90 degree corners or four 135 degree corners.

Picture 4: Omega seals between the structures of the canal to the Ship lift of Strépy Thieu - Belgium



Figure 3: Application of flat omega seals in for instance aqueducts.

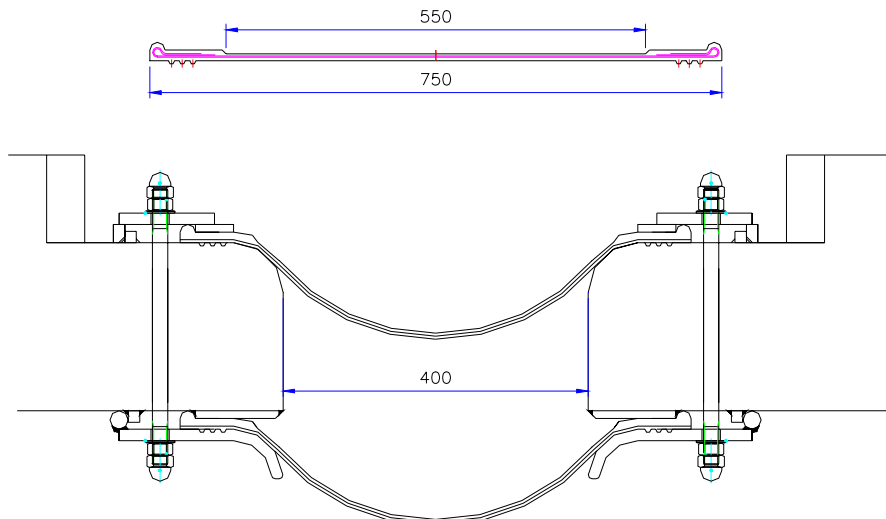



TRELLEBORG

Picture 5& 6: Applications of omega seals in sluices - Germany





TRELLEBORG

Another special application is to install the flanges of the omega seal under 90 degrees. This is used for instance as a watertight solution between a bridge deck or U-shaped canal and an abutment, see figures below.

Figure 4: Omega seals with flanges perpendicular.

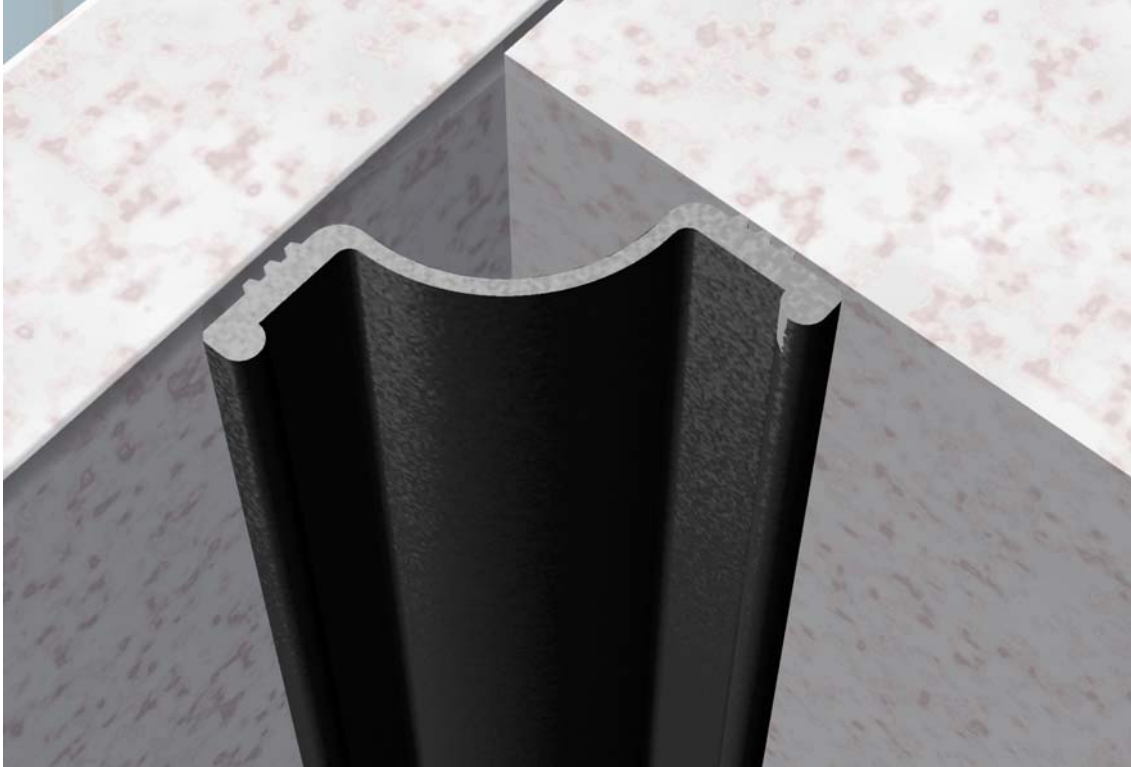
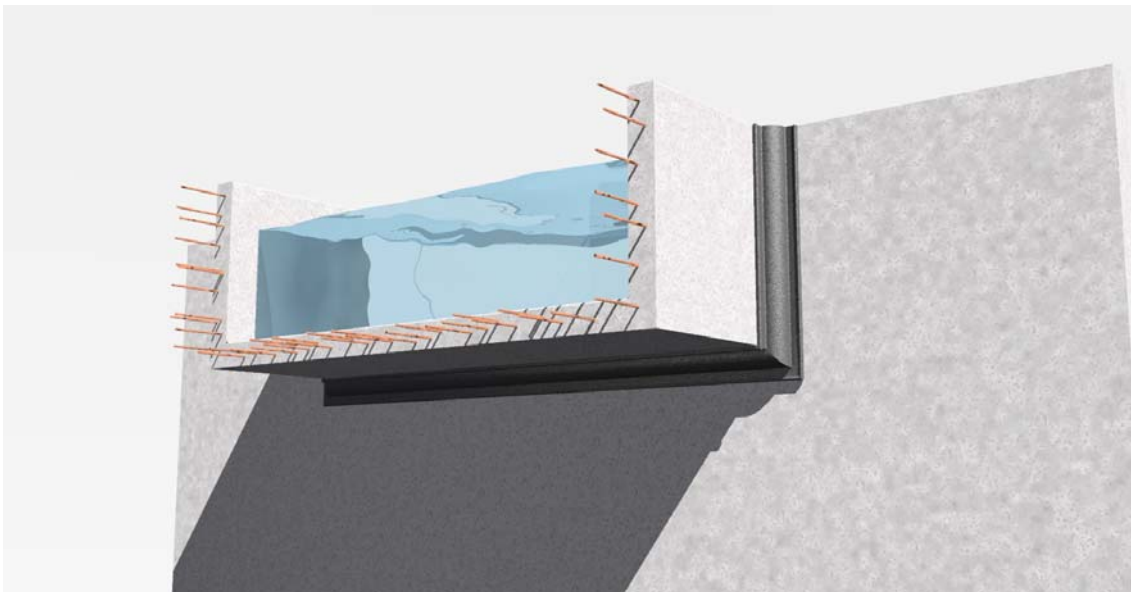

Figure 5: U-frame of Omega seals with flanges perpendicular.



4 Product range Omega

For economic solutions Trelleborg Ridderkerk BV has selected a standard range of 4 types of Omega seals, which accommodate most required performance specifications. As many corner moulds for the standard types are available, no additional tooling costs have to be taken in account. When required other corners may be manufactured. Selecting one of the standard range provides for shorter delivery times. In table 1 the complete range of all presently available Omega joints, standard and non-standard are shown. The complete range of flat omega seals is shown in Table 2. The following 4 types of Omega seal are in the standard range, see product drawings in appendix A:

- OS 240-40 weight 4,5 kg/m;
- OS 300-70 weight 5,4 kg/m;
- OS 360-100 weight 7,1 kg/m.
- OS 400-100 weight 8,8 kg/m.

The explanation of the type code is:

- OS = Omega Seal
- 300 = nominal width in mm
- 70 = radius of the curve in mm

Table 1: Product range of Omega type

| Omega type | Total width | Arc radius | (Non) standard |
|--------------|-------------|------------|----------------|
| OS 130-15 | 130 | 15 | non standard |
| OS 170-20 | 170 | 20 | non standard |
| OS 180-40 | 180 | 40 | non standard |
| OS 225-59 | 225 | 59 | non standard |
| OS 240-40 | 240 | 40 | standard |
| OS 250-40 | 250 | 40 | non standard |
| OS 270-50 | 270 | 50 | non standard |
| OS 277-70 | 277 | 70 | non standard |
| OS 300-70 | 300 | 70 | standard |
| OS 300-70 FM | 300 | 70 | non standard |
| OS 320-81 | 320 | 81 | non standard |
| OS 350-91 | 350 | 91 | non standard |
| OS 360-100 | 360 | 100 | standard |
| OS 400-100 | 400 | 100 | standard |

Table 2: Product range of flat Omega type

| Flat type | Total width | (Non) standard |
|-----------|-------------|----------------|
| WS 260-25 | 260 | non standard |
| W 5U | 330 | non standard |
| WS 365-10 | 365 | non standard |
| WS 400-8 | 400 | non standard |
| WS 483-10 | 483 | non standard |
| WS 650 | 659 | non standard |
| WS 750 | 750 | non standard |
| WS 1400 | 1380 | non standard |

5 Design application data

In Appendix C the design application data for the standard range of Omega seals is shown. The graphs show the allowable movements of the Omega seal for various water depths/pressures. The maximum water pressure is inclusive of a safety factor of 2.5 on the breaking strength of the Omega wall construction. The regressive line shows that when the gap under the Omega arc increases, less water pressure is allowed.

The values are based on Omega seals with 2 nylon plies. For larger water depths with the same movement capacity the seal type OS 360-100 and OS 400-100 can be improved by application of 3 nylon plies.

6 Clamping system

Two systems are most common. A galvanised steel strip is mounted with bolts through the rubber flange. This system is possible for water pressure not more than 5 m and movements up to 30 mm. The disadvantage of this system is that holes through the flange lower the sealing capacity. In general the hole is drilled through the second sealing groove, this results in two of the 3 sealing barriers being unused.

Figure 6: Installation with strip and bolts through flange of the omega seal.

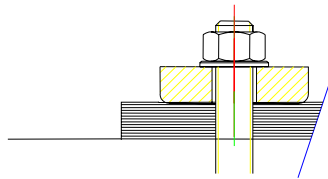

Trelleborg Ridderkerk prefers the system in which the flange is clamped, while the bolt fastens the galvanised steel parts, see below and in appendix B. Special corner pieces are required in order to prevent leakage in the corners. Trelleborg Ridderkerk can assist in the design of such a special corner clamp. This system provides optimum safety and prevention of leakage. The seal installation is also easier.

Figure 7: Conventional clamping system with bolts outside flange of the seal.

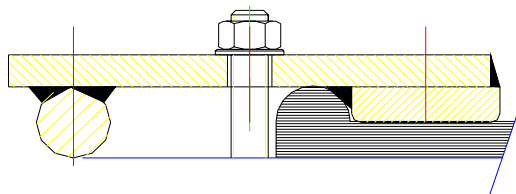

For both systems it is necessary that the Omega seal to be mounted onto a smooth surface consisting of either a galvanised steel plates or a smooth concrete finish.

The pressure differential across the Omega seal wall results in tension forces within the wall construction of the seal. The magnitude of these forces depends on the seals cross section radius. The radius can be calculated from the length of the seal from flange to flange and from distance between the 2 flanges. The forces in the wall of the seal are transferred into the clamping system. These forces are restrained by a combination of clamping force due to the bolts and friction under the clamping strip. Typical clamping arrangements for the standard range Omega seals are shown in Appendix B. The initial

clamping force is subjected to relaxation over time. The relaxation of the flange is 5 to 6% per decade, which results in a considerable loss of force over time and this should be considered in the design of the required initial clamping force

The exact dimensions and sizes of the required clamping system and fixing bolts have to be calculated on a project basis and can be done by Trelleborg Ridderkerk upon request.

Trelleborg Ridderkerk will forward storage instructions in accordance with the international standard ISO 2230.

The installation of the Omega seal requires special techniques. Because of this we recommend to supervise the installation of at least the first omega seal by a specialist of Trelleborg Ridderkerk. We shall provide an installation procedure to ensure correct and proper installation. Trelleborg Ridderkerk is also able to advice on the required bolt tension. The effect of relaxation shall be incorporated in this.

7 Policy quality, environment, safety and health

The policy of Trelleborg Ridderkerk BV is to design, produce and deliver rubber products which are in accordance with the customers' requests, needs and expectations. Our policy is based on the Trelleborg Group policy statement 'Code of Conduct', which is presented on the website www.trelleborg.com.

During the development of products and processes the environment, safety and health are integral to the process. Trelleborg Ridderkerk BV is using an integrated management system which complies with international standards such as ISO 9001, ISO 14001 and SCC**.

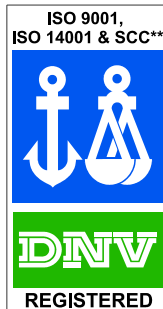

Each Omega seal is carefully checked on the following aspects:

1. Rubber properties;
2. Reinforcement properties;
3. Visual inspection of the Omega seal;
4. The dimensions of the Omega seal.

These standard checks guarantee a high quality which has been proven for decades.

Appendix A: Standard range of Omega seal types

OMEGA OS 240-40

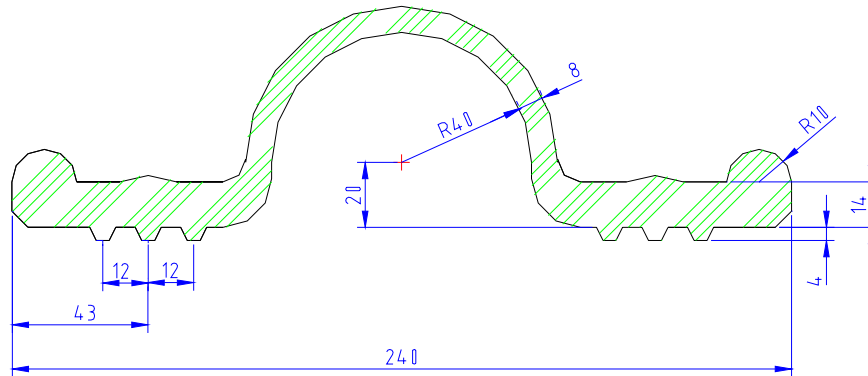

OMEGA OS 300-70

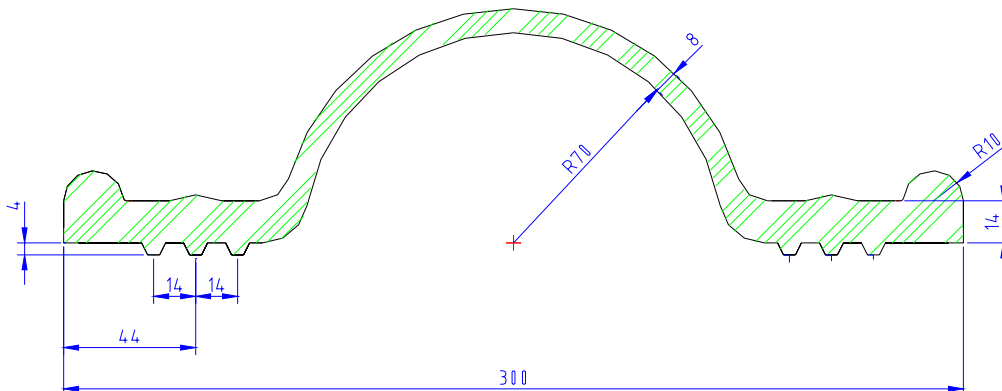

OMEGA OS 360-100

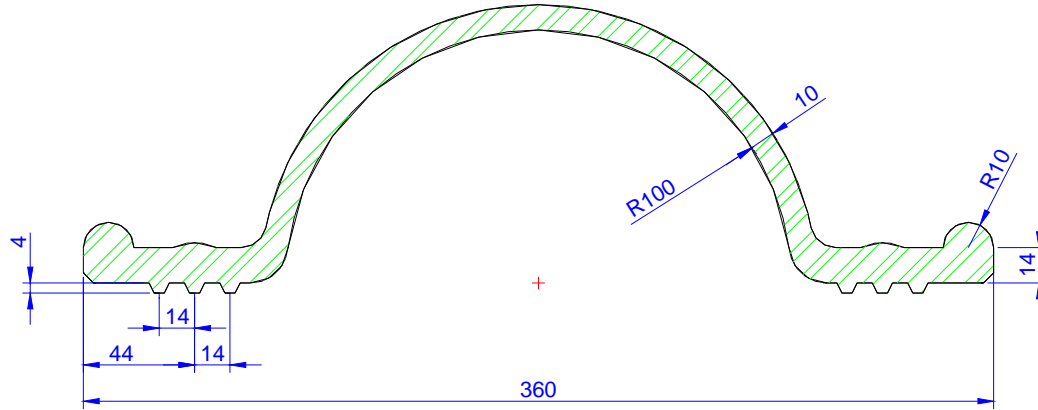

OMEGA OS 400-100

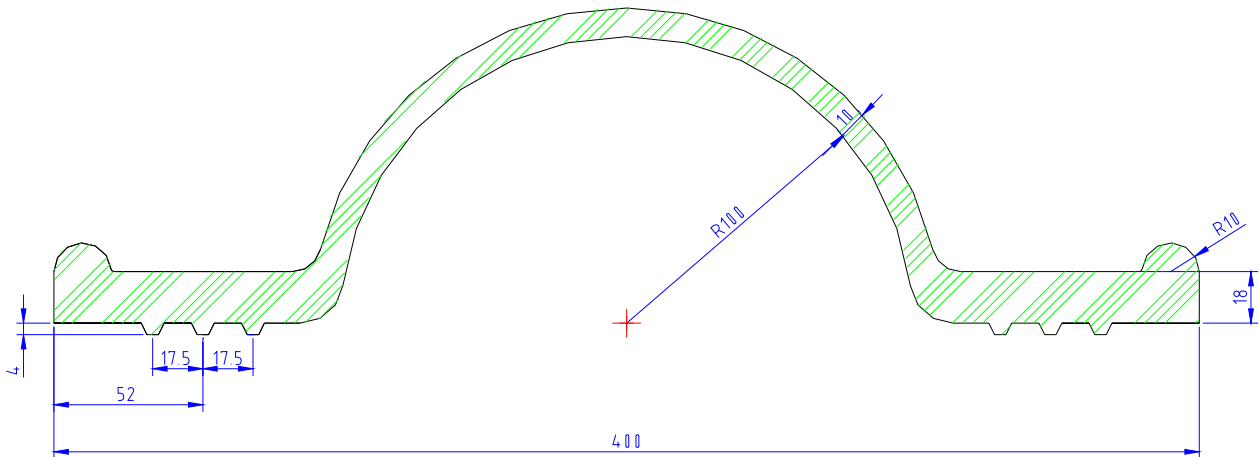

Appendix B: Typical clamping system for Omega seals

Typical clamping system of OMEGA OS 240-40

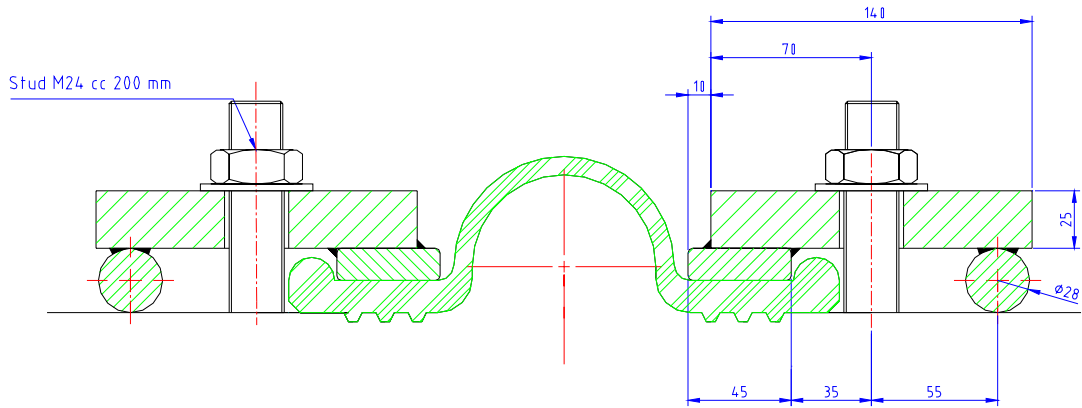

Typical clamping system of OMEGA OS 300-70

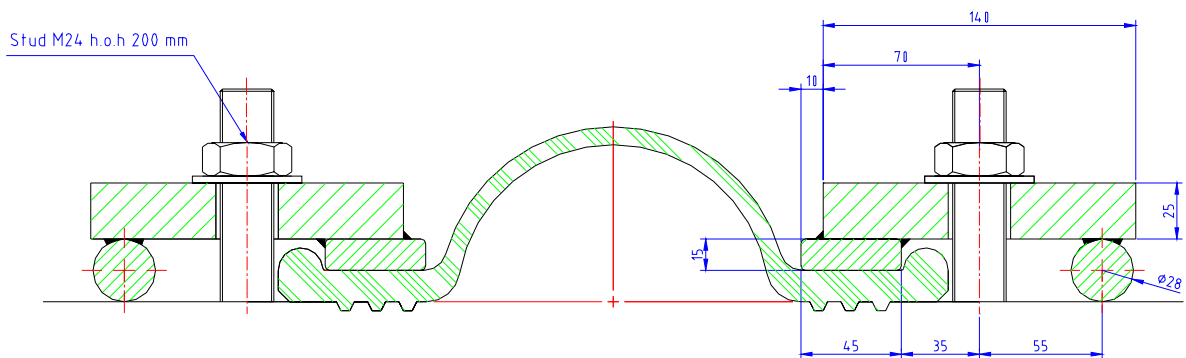

Typical clamping system of OMEGA OS 360-100

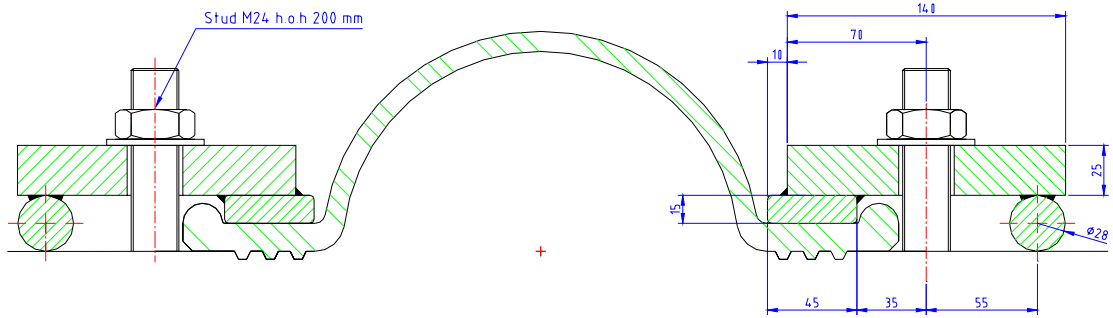

Typical clamping system of OMEGA OS 400-100

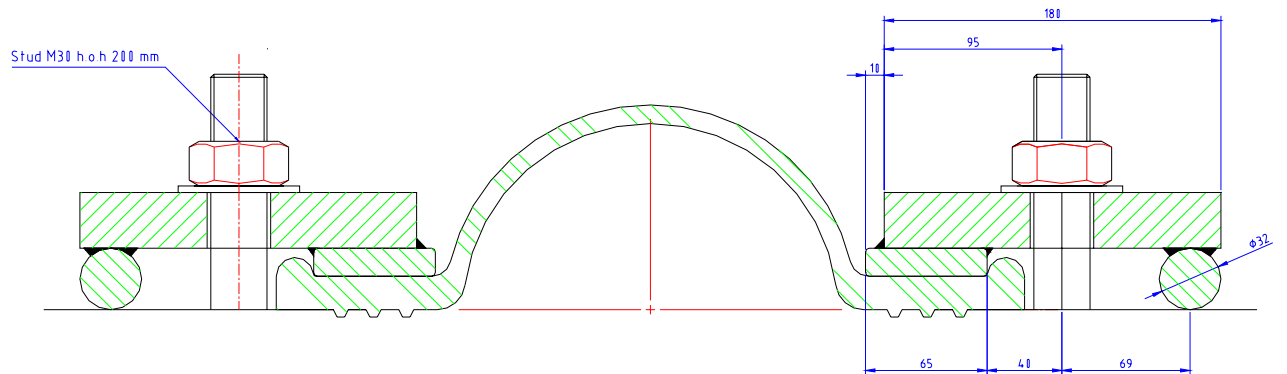

Appendix C: Diagram of allowable deflection and water pressure

OS-240/40 & OS-250/40, Length vs Pressure
 Application range, including safety factor 2.5

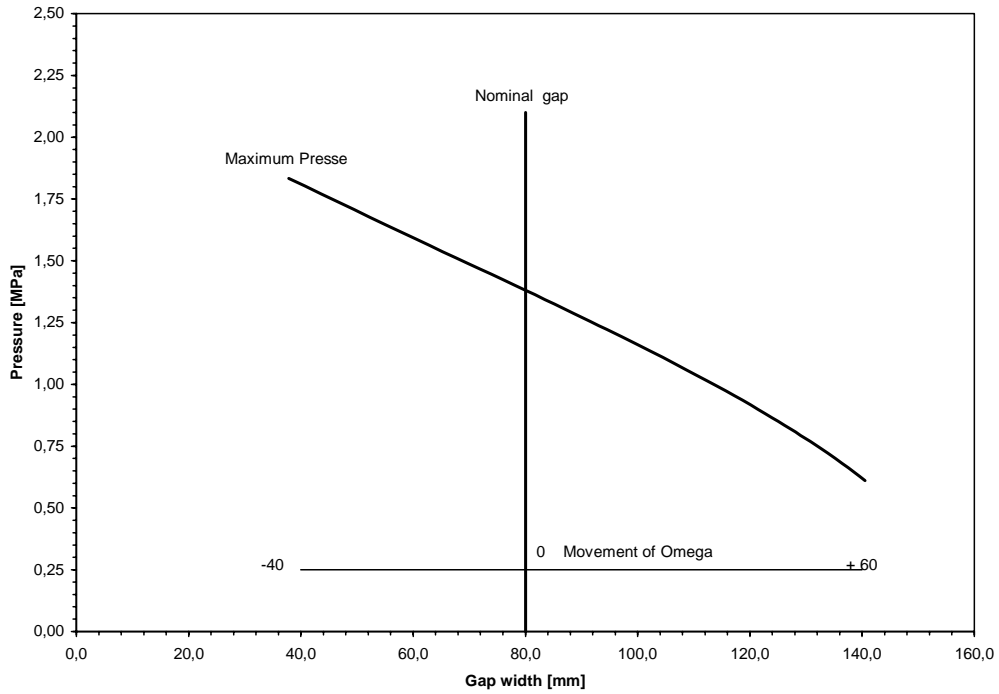

OS-300/70 (FM), Length vs Pressure
 Application range, including safety factor 2.5

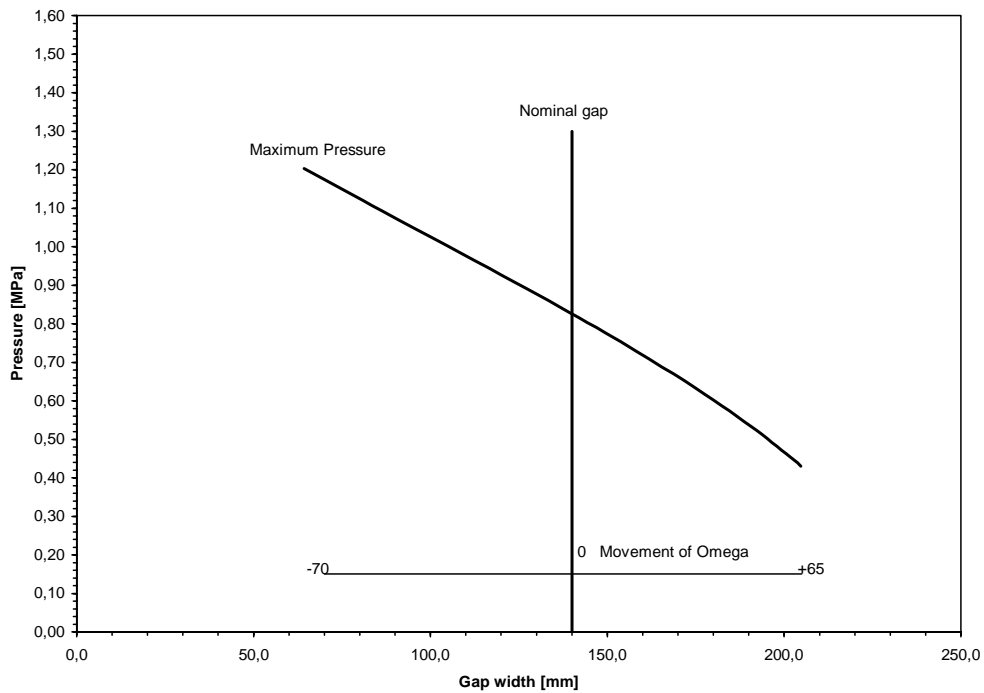

OS-360/100 & OS-400/100, Length vs Pressure
Application range, including safety factor 2.5

