



Chevron Spring



Chevron Spring

Metalastik® Chevron Springs are operating world wide in a diversity of service applications including LRV, Metro, Freight wagons, High Speed Passenger Coaches and Locomotives. Axlebox load capacities range from 16 kN to 120 kN and vertical deflections from 12 mm to 100 mm.

Chevron Springs provide three modes of flexibility for axlebox primary suspensions. The suspension properties are achieved by fitting the springs in a vee formation and with shear and compression compliance within the rubber elements. Improved ride characteristics are provided with the advantages of simplicity, long service life and low maintenance costs.

Abutting end plates can be produced in light alloy to match with similar material interfaces at the axlebox or vehicle frame.

The included angle of the chevron plates can be varied between 90 deg. and 140 deg. at the design stage thereby allowing stiffness characteristics to be optimised to suit bogie designers

About Trelleborg Industrial AVS

Over 100 years of experience as Metalastik and Novibra, today Trelleborg Industrial AVS make improvements people can physically feel. From smoother travel to quieter, more efficient machines, we make life feel better. With quality, testing and compliance built in, we're in it for the long haul, ensuring your solution still works, over an extended and often arduous life-cycle.

With three state-of-the-art manufacturing plants across the globe, our experience in rubber to metal bonding enhances several industries, including off-highway vehicles, rail and mass transit, marine and energy and general industry.

We offer an end-to-end service, to take you from concept through design, manufacturing and testing to delivery. This reduces the complexity of supply, helping you cut costs, mitigate risk and receive on time, on budget delivery.

Trelleborg IAVS is part of Trelleborg Group, which employs 15,000 people in over 40 countries. Whatever your challenge, whatever your role and wherever you are, we are nearby to offer expert knowledge and quality solutions.



Chevron Springs

Spring Characteristics

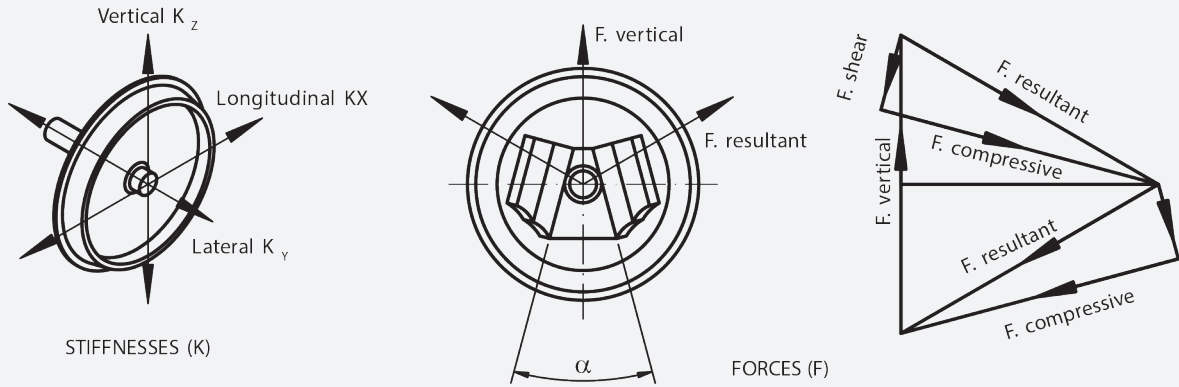

The three modes of flexibility for axlebox suspension are shown here. Springs are fitted inclined at an angle to the vertical axis, loading the rubber layers in shear and compression.

Values quoted for lateral and longitudinal stiffness may vary with vertical deflection. The longitudinal stiffness value applies when the elastic centre of the two Chevron springs is at the journal centre height. If the elastic centre is above or below the centre of the journal, the longitudinal stiffness at the journal will be less than the value quoted. Metalastik® Chevron springs may be fitted to two bearing or single self-aligning bearing axleboxes. For stability with self aligning bearings, the elastic centre of the Chevron springs in their laden position should not be above the journal centre height. The temperature at the axlebox faces adjoining the Chevron springs should not exceed 60 degrees C. A typical force diagram is shown above.

Installation

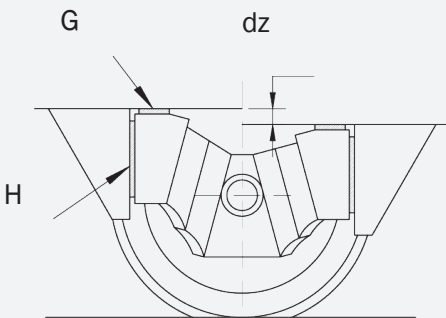

The vertical deflection (dz) may vary due to creep, Joule effect and stiffness tolerances. Shims (G) should be included for height adjustment. Shims (H) are sometimes necessary for accurate alignment of axes.

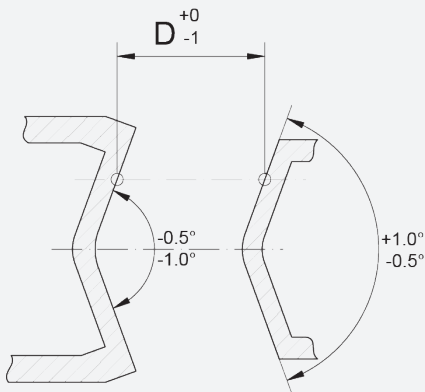

Tolerances

Tolerances at the adjoining faces should be as shown

Spring fixings

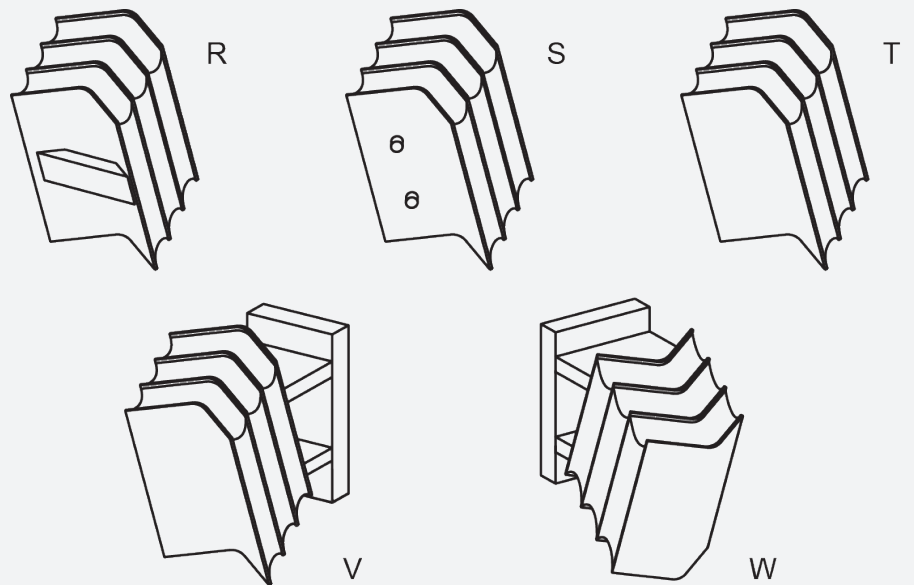

Springs can be supplied with alternative methods of location as shown in the diagram, namely with cross bar (R), dowel pins (S), or edge location (T). Location on the bogie frame is normally on the plate edge. Springs can be supplied with brackets for direct and easy fitting to the bogie frame (ref . figs V & W)

CLASSIFICATION

Springs listed on the following pages are classified in the following ranking order :

- 1) Chevron angle - 90o, 106o, 120o and 140o.
- 2) Listings in each of the above groups are then ranked progressively in terms of deflection capacity followed by load capacity.



Chevron Spring

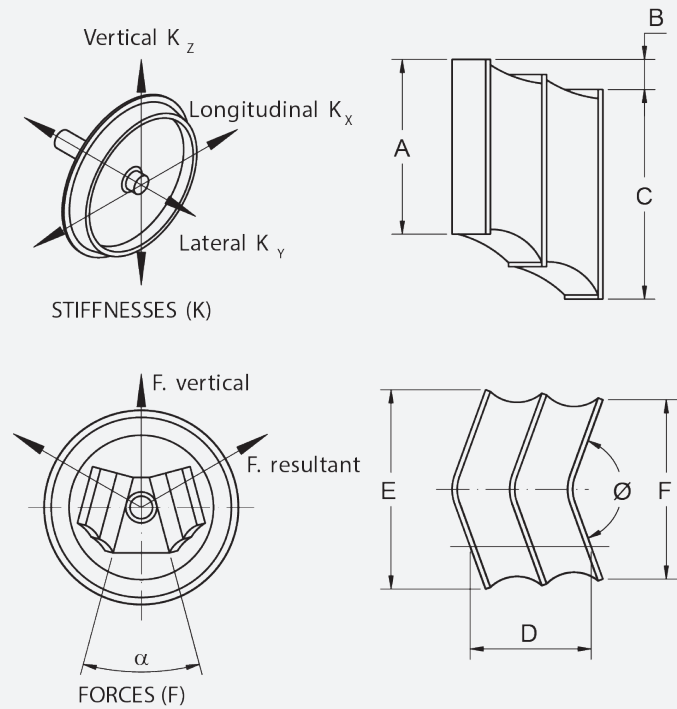

Vertical deflection, load and all stiffnesses refer to two Chevron springs at one axlebox

90° Chevron Angle 11-25 mm Vertical Deflection

TYPE	VERTICAL LOAD (KN)	VERTICAL DEFLECTION (KN/MM)	VERTICAL STIFFNESS (KN/MM)	LATERAL STIFFNESS (KN/MM)	LONGITUDINAL STIFFNESS (KN/MM)	INSTALLED ANGLE	DIMENSIONS IN MM						WEIGHT (KG)
							A	B	C	D	E	F	
17-1085	19	11	1.7	2.1	8	40	112	14.3	125	91	110	84	2.5
17-1084	24	11	2.1	4	11	40	152	14.3	165	91	110	84	3.4
17-1211	27	11	2.4	5.0	14	40	190	14.3	203	91	110	84	4.2
17-0424	19	19	1.0	1.1	3	40	127	29	178	88	110	76	3.6
17-1344	27	19	1.4	3.9	10	40	165	29	152	88	126	76	4.6
17-0375	35	52	1.4	2.5	6	40	200	32	216	113	209	121	7.6

106° Chevron Angle 33-45 mm Vertical Deflection

TYPE	VERTICAL LOAD (KN)	VERTICAL DEFLECTION (KN/MM)	VERTICAL STIFFNESS (KN/MM)	LATERAL STIFFNESS (KN/MM)	LONGITUDINAL STIFFNESS (KN/MM)	INSTALLED ANGLE	DIMENSIONS IN MM						WEIGHT (KG)
							A	B	C	D	E	F	
17-1964	25	33	0.7	1.25	13.5	22	185	48	229	104	130	100	6
17-2167	58	34	1.7	3.8	18	22	165	48	216	115	231	152	13.3
17-1083	82	34	2.4	7.2	33	22	197	48	248	115	231	152	15.4
17-1593	94	41	2.3	10	46	22	227	48	270	130	265	175	17
17-1963	32	43	0.8	1.5	12	22	169	38	223	125	176	132	9
17-1760	41	45	0.9	4.2	10	22	188	29	282	150	252	152	19
17-1453	63	45	1.4	7.6	19	22	227	44	301	150	273	157	22.7
17-1153	90	45	2.0	7.0	32	22	203	64	273	150	252	152	21



Chevron Springs

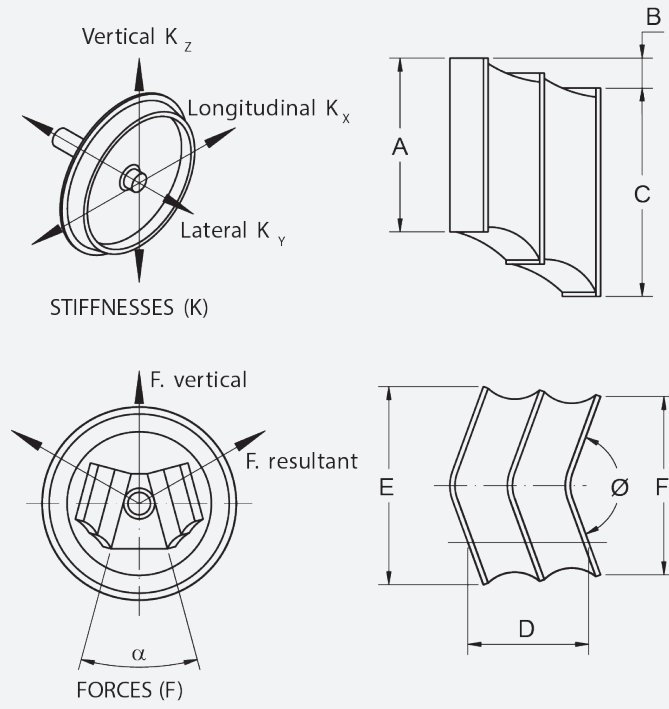

Vertical deflection, load and all stiffnesses refer to two Chevron springs at one axlebox

120° Chevron Angle 21-32 mm Vertical Deflection

TYPE	VERTICAL LOAD (KN)	VERTICAL DEFLECTION (KN/MM)	VERTICAL STIFFNESS (KN/MM)	LATERAL STIFFNESS (KN/MM)	LONGITUDINAL STIFFNESS (KN/MM)	INSTALLED ANGLE	DIMENSIONS IN MM						WEIGHT (KG)
							A	B	C	D	E	F	
17-1610	35	21	1.7	3.5	25	22	181	23	210	64	159	116	4.6
17-1866	33	30	1.1	3.6	16	22	176	30	216	88	192	143	8.3
17-0888	39	30	1.3	3.1	25	22	138	30	178	88	192	143	8.2
17-0508	55	30	1.8	3.7	30	22	176	30	216	88	192	143	10.4
17-2023	35	31	1.15	2.6	6	24	260	60	269	110	136	120	11
17-1747	26	32	0.8	0.7	0.9	22	200	50	213	95	120	115	5.5
17-1525	35	32	1.2	2.0	13	22	225	62	260	95	140	120	7.0

120° Chevron Angle 35-40 mm Vertical Deflection

TYPE	VERTICAL LOAD (KN)	VERTICAL DEFLECTION (KN/MM)	VERTICAL STIFFNESS (KN/MM)	LATERAL STIFFNESS (KN/MM)	LONGITUDINAL STIFFNESS (KN/MM)	INSTALLED ANGLE	DIMENSIONS IN MM						WEIGHT (KG)
							A	B	C	D	E	F	
17-2057	40	35	1.1	2.6	1.2	30	262	68	262	147	202	130	12
17-2085	47	36	1.3	3.2	16	24	225	50	255	93	150	145	8
17-1676	24	40	0.6	1.0	6	22	251	65	260	109	130	138	8
17-1371	32	40	0.8	3.0	10	22	146	40	197	115	203	143	12.3
17-0885	40	40	1.0	2.0	17	22	127	40	178	115	203	143	8.3
17-1727	40	40	1.0	1.5	20	22	169	38	223	116	181	132	8.6
17-1376	48	40	1.2	1.8	26	22	194	38	248	116	181	132	9.8

Chevron Springs

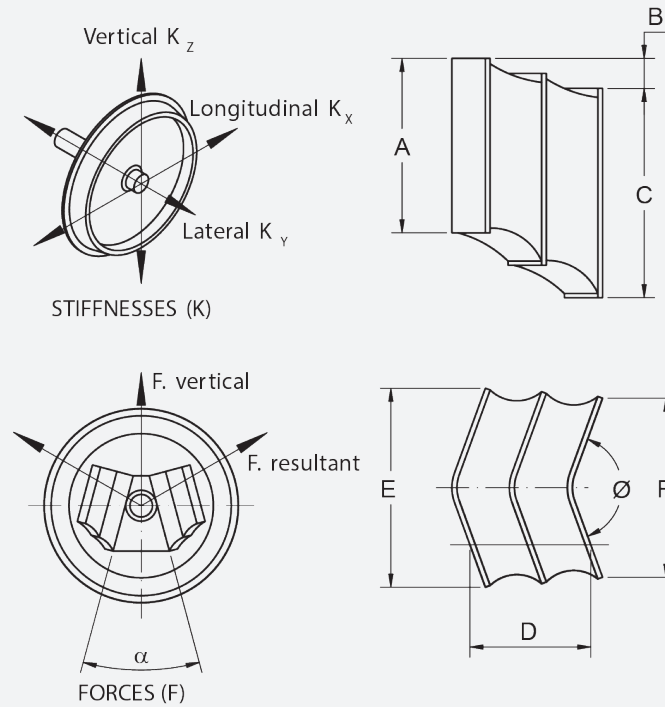

Vertical deflection, load and all stiffnesses refer to two Chevron springs at one axlebox

120° Chevron Angle 40-56 mm Vertical Deflection

TYPE	VERTICAL LOAD (KN)	VERTICAL DEFLECTION (KN/MM)	VERTICAL STIFFNESS (KN/MM)	LATERAL STIFFNESS (KN/MM)	LONGITUDINAL STIFFNESS (KN/MM)	INSTALLED ANGLE	DIMENSIONS IN MM						WEIGHT (KG)
							A	B	C	D	E	F	
17-1331	56	40	1.4	3.0	27	22	165	40	216	116	223	165	10.5
17-1467	56	40	1.4	4.6	24	22	200	40	255	116	223	165	13.5
17-1001	84	40	2.1	3.6	37	22	191	40	241	116	203	143	127
17-1574	31	51	0.6	1.8	7	22	178	57	241	149	202	116	11.1
17-1457	56	51	1.1	3.0	13	22	253	90	318	149	202	116	16
17-1151	61	51	1.2	1.6	23	22	178	57	241	149	202	116	11.8
17-1786	56	56	1.0	3.7	13	22	240	82	266	162	244	160	18.6

140° Chevron Angle 59-78 mm Vertical Deflection

TYPE	VERTICAL LOAD (KN)	VERTICAL DEFLECTION (KN/MM)	VERTICAL STIFFNESS (KN/MM)	LATERAL STIFFNESS (KN/MM)	LONGITUDINAL STIFFNESS (KN/MM)	INSTALLED ANGLE	DIMENSIONS IN MM						WEIGHT (KG)
							A	B	C	D	E	F	
17-2003	47	69	0.6	0.25	3.2	26	280	114	271	200	208	204	21
17-2185	32	71	0.45	0.35	1.7	26	280	114	271	200	208	204	21
17-1621	62	78	0.8	0.4	6.5	22	280	123	230	198	230	226	25.5



WWW.TRELLEBORG.COM/ANTI-VIBRATION-SOLUTIONS

For further information visit our website or e-mail industrialavs@trelleborg.com

The content in this datasheet was correct at the time of printing, but is subject to change without notice.