



HD Cushyfloat

17/4726

HD Cushyfloat

The latest generation of Metalastik® Cushyfloat™ is a completely new and innovative design which offers engine manufacturers and boat builders maximum versatility. This product has multiple performance benefits for customers whose requirements may be varied and challenging for conventional solutions.

The HD Cushyfloat has excellent performance characteristics with:

- Up to 10mm linear vertical deflection, with low horizontal stiffnesses. This enables improved vibration isolation - even at the low end of the engine speed range.
- Vertical and lateral buffering within the design limits the movement of the engine in tough service conditions.

The HD Cushyfloat provides simplicity for engines manufacturers and end users with:

- an interchangeable footprint with existing mountings; minimizing retrofit installation issues.
- The entire range can be formulated from just three rubber mixes; therefore reducing inventory requirements, and the complexity of product selection.
- Installation is aided by sighting grooves so that it is easy to align the engine, and ensure the correct load distribution.
- More cost effective product life and serviceability due to its modular design. Upon refurbishment, the outer casting can be re-used.

About Trelleborg Industrial AVS

Over 100 years of experience as Metalastik and Novibra, today Trelleborg Industrial AVS make improvements people can physically feel. From smoother travel to quieter, more efficient machines, we make life feel better. With quality, testing and compliance built in, we're in it for the long haul, ensuring your solution still works, over an extended and often arduous life-cycle.

With three state-of-the-art manufacturing plants across the globe, our experience in rubber to metal bonding enhances several industries, including off-highway vehicles, rail and mass transit, marine and energy and general industry.

We offer an end-to-end service, to take you from concept through design, manufacturing and testing to delivery. This reduces the complexity of supply, helping you cut costs, mitigate risk and receive on time, on budget delivery.

Trelleborg IAVS is part of Trelleborg Group, which employs 15,000 people in over 40 countries. Whatever your challenge, whatever your role and wherever you are, we are nearby to offer expert knowledge and quality solutions.



HD Cushyfloat 17/4726

Technical Drawing

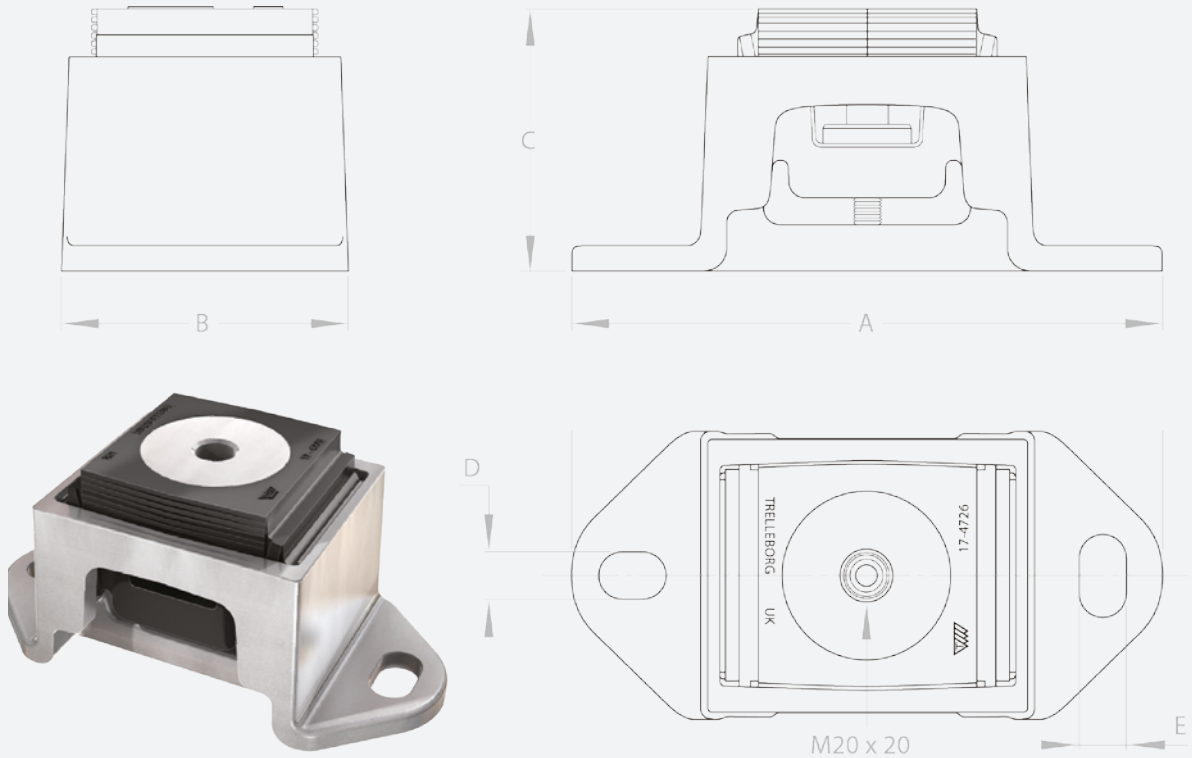

Product Data

DRAWING No.	PART No.	TYPE	DIMENSIONS (mm)					MAX LOAD (Kg)	MAX LOAD WITH THRUST (Kg)	MAX THRUST (Kn)		STATIC STIFFNESS (N/mm)	MAX BOLT TORQUE (NM)	WEIGHT (Kg)
			A	B	C	D	E			CONTINUOUS	INTERMITTENT			
17-4726-1	10-02308	40 IRH						220	155	2.45	3.19	270	170	5
17-4726-1	10-02108	50 IRH	228	111	101	18	18	320	220	3.67	4.78	390	170	5
17-4726-1	10-02109	60 IRH						470	330	5.51	7.16	575	170	5
17-4792-1	10-02159	40 IRH						530	370	5.33	6.93	650	170	5.15
17-4792-1	10-02114	50 IRH	228	111	101	18	18	735	515	7.96	10.35	900	170	5.15
17-4792-1	10-02160	60 IRH						980	685	14.7	19.11	1200	170	5.15



WWW.TRELLEBORG.COM/ANTI-VIBRATION-SOLUTIONS

For further information visit our website or e-mail industrialavs@trelleborg.com

The content in this datasheet was correct at the time of printing, but is subject to change without notice.

